



# **FORTSUL** SC

EQUIPAMENTOS AGRÍCOLAS



**FORTALECENDO  
PARCERIAS**



[www.fortsulsc.com.br](http://www.fortsulsc.com.br)

Fone: (48) 3660-0818 - Rod SC 108, Km 330,95 - Bairro Murialdo - CEP: 88870-000 - Orleans/SC

***VISITE NOSSO SITE!***

**CONHEÇA NOSSOS PRODUTOS**



**[www.fortsulsc.com.br](http://www.fortsulsc.com.br)**

***SIGA-NOS*** NAS  
***REDES SOCIAIS***



**@fortsulsc.ols**



# **FALE CONOSCO!**

ENTRE EM CONTATO CONOSCO PELO:

**SITE, REDES SOCIAIS, WHATSAPP, FONES...**

**SOLICITE ORÇAMENTOS,  
VISITAS DE REPRESENTANTES...**

## REPRESENTANTES

**Nome: Adriano Willemann**

**Fone/WhatsApp: (49) 9 9132-6618**

**Região.:**

**Urubici, Rio Rufino, Bom Retiro, Urupema, São Joaquim, Bom Jardim**

**Nome: Vagner Cristiano Dias**

**Fone/WhatsApp: (48) 9 9620-1446**

**Região.:**

**Angelina, Ituporanga, Imbuia, Vidal Ramos, Chapadão do Lageado,  
Alfredo Vagner, Rancho Queimado, Leoberto Leal, Major Gercino,  
Nova Trento, Tijucas, Vidal Ramos, São João Batista.**

**Comercial FortSul SC**

**Fone/WhatsApp: (48) 3660-0818**



**FALE CONOSCO!**  
**48 3660-0818**





### Grade Niveladora Hidráulica com Pino de Regulação

- Nº de Discos: 24-28-32-36
- Tamanho do Disco: 20" e 22"
- Espessura do Disco: 3,5 mm
- Espaçamento: 185 a 195
- Mancais a Óleo e Graxa
- Modelo: GN28DCR
- Modelo: GN32DCR
- Modelo: GN36DCR
- Modelo: GN44DCR



### Grade Niveladora em V

- Nº de Discos: 24-28-32-36
- Tamanho do Disco: 20" e 22"
- Espessura do Disco: 4,5 mm
- Espaçamento: 190 a 230
- Mancais a Óleo
- Modelo: GN28DCR
- Modelo: GN32DCR
- Modelo: GN36DCR
- Modelo: GN44DCR



### Grade Niveladora com Controle

- Nº de Discos: 28-32-36-44
- Tamanho do Disco: 20 e 22"
- Espessura do Disco: 4,5mm
- Espaçamento: 190 a 230
- Mancais a Óleo
- Controle remoto
- 2 Pneus 650 x 16 x 8L
- Modelo: GN28DCR
- Modelo: GN32DCR
- Modelo: GN36DCR
- Modelo: GN44DCR



### Grade Aradora

- Nº de Discos: 12-14-16-18-20
- Tamanho do Disco: 26" e 28"
- Espessura do Disco: 6,00 a 7,5mm
- Espaçamento: 230 a 270
- Mancais a Óleo e Graxa
- Controle Remoto
- 2 Pneus 650 x 16 x 8L
- Peso mínimo de 1.000 kg
- Modelo: GA18D-26
- Modelo: GA18D-28
- Modelo: GA20D-26
- Modelo: GA20D-28
- Modelo: GA14D-26
- Modelo: GA14D-28
- Modelo: GA16D-26
- Modelo: GA16D-28



### Plaina Traseira Hidráulica

- Medida: 220 cm a 300 cm
- Ângulo Vertical: 0°, 10°, 20°
- Ângulo Horizontal: 0°, 15°, 30°
- Modelo: PTH2200
- Modelo: PTH2500
- Modelo: PTH2800
- Modelo: PTH3000



### Plaina Traseira Reversível

- Medida: 190 cm a 300 cm
- Ângulo Vertical: 0°, 10°, 20°
- Ângulo Horizontal: 0°, 15°, 30°
- Modelo: PTR1900
- Modelo: PTR2200
- Modelo: PTR2500
- Modelo: PTR2800
- Modelo: PTR3000



### Guincho Traseiro

- Comprimento total: 200 cm
- Elevação: 230 cm
- Capacidade: 1.000 kg
- Modelo: GTM800

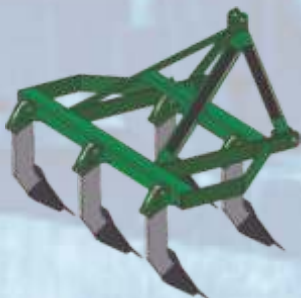

### Arado Subsolador com Pino ou Abraçadeira

- Medida: L 170 a 240 cm X C 130 cm X A 115 cm
- Altura da Haste: 67 cm
- Modelo 5 Haste: AS5HP
- Modelo 7 Haste: AS5HP



### Arado Borboleta 2 Haste com Flange

- Medida: L 170 cm X C 70 cm X A 113 cm
- Altura da Haste: 67 cm
- Modelo: AB2HF



### Arado Papa Terra 3 Haste com Flange

- Medida: L 150 cm X C 110 cm X A 112 cm
- Altura da Haste: 66 cm
- Modelo: APT3HF



### Carreta Metálica Hidráulica Com Porta

- Medida: L 170 cm X C 300 a 420 cm X A 50 a 120 cm
- M<sup>3</sup> 5,5m<sup>3</sup> a 12m<sup>3</sup>
- Carroceria em chapas 2,65mm e Chassi estrutural com espessura 6,85mm
- Capacidade: 5, 6 e 8 toneladas
- Basculamento hidráulico
- Rodado Tandem e rodado Duplo
- Abertura com engate rápido
- Modelo: CMH5000
- Modelo: CMH6000
- Modelo: CMH8000



### Carreta Caçamba Hidráulica

- Medida: L 170 cm X C 300 a 420 cm X A 60 a 120 cm
- Carroceria em chapas 3,55mm e Chassi estrutural com espessura 6,85mm
- Capacidade: 5, 6 e 8 toneladas de 5,5m<sup>3</sup> a 12m<sup>3</sup>
- Basculamento hidráulico
- Rodado Tandem e rodado Duplo com pneus 750/16 novos 10 lonas
- Abertura com engate rápido
- Modelo: CCH5000
- Modelo: CCH6000
- Modelo: CCH8000



### Distribuidor de Calcário e Composto Orgânico

- Comprimento: 460 cm
- Largura: 200 cm
- Altura: 165 a 280 cm
- Volume de Carga M<sup>3</sup>: 1,60 a 4,90
- Modelo: DCO 6000
- Modelo: DCO 3500
- Rodado: Simples
- Rodado: Tander
- Rodado: Duplo
- Rodado: Pantaneiro



### Queimador de Cavaco

- Forno para aviários Sistema anti fogo
- Alimentador de cavaco com sistema de esteira
- Todo sistema automatizado.



### Pá Carregadeira Traseira Manual e Hidráulica

- Medidas: L 100 cm X C 70 cm X A 50 cm
- Capacidade: 500 kg / 280 L
- Modelo: PCTM100

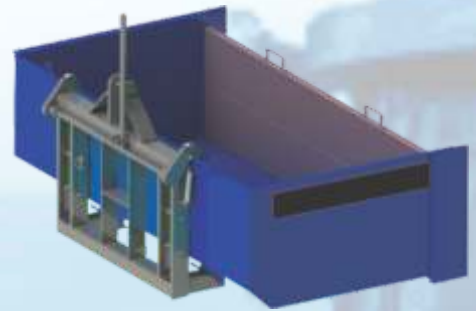

### Plataforma de Ferro Raspo

- Medida 1: L 240 cm X C 100 cm X A 60 cm
- Capacidade: 1000 kg
- Basculamento Manual e Hidráulico
- Modelo: PFR1000
- Medida 2: L 205 cm X C 100 cm X A 60 cm
- Capacidade: 800 kg
- Basculamento Manual
- Modelo: PFR800
- Medida 3: L 1150 cm X C 100 cm X A 60 cm
- Basculamento Manual
- Modelo: PFR175

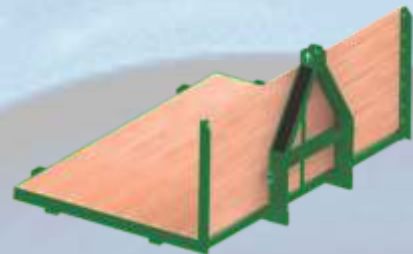

### Plataforma de Madeira Fixa

- Medida: L 180 cm X C 100 cm X A 70 cm
- Capacidade: 800 kg
- Modelo: PFM800



### Garfo de Zorra

- Comprimento: 110 e 180 cm
- Largura: 83 cm
- Altura: 100 cm



# Piscicultura



## RAÇÃO DE PEIXES



## EXTRUSORA DE MASSAS

- Extrusora para produção de ração de peixes;
- Capacidades de 100 a 1000 kg hora;
- Produção de Granulometria de 2 a 8 mm para cada fase da produção;
- Sistema todo automatizado.



## SECADOR

- Secagem rápida e uniforme;
- Ração pronta para alimentar a produção;
- Sistema todo automatizado.



## MAIOR PRODUTIVIDADE EM MENOR TEMPO



# Secador de Grãos

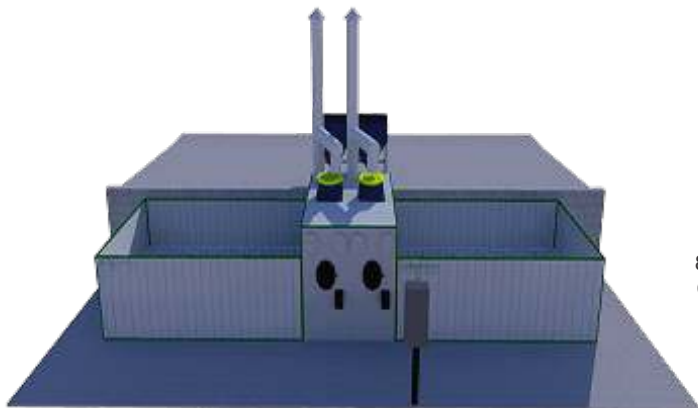

**CAPACIDADE:**  
8.000L cada caixa  
Comp. Total: 10m  
Largura: 2m  
Altura: 1m

## ALVENARIA

**CAPACIDADE:**  
15.000L cada caixa  
Comp. Total: 12m  
Largura: 3m  
Altura: 1m

**CAPACIDADE:**  
18.000L cada caixa  
Comp. Total: 12m  
Largura: 3m  
Altura: 1,25m

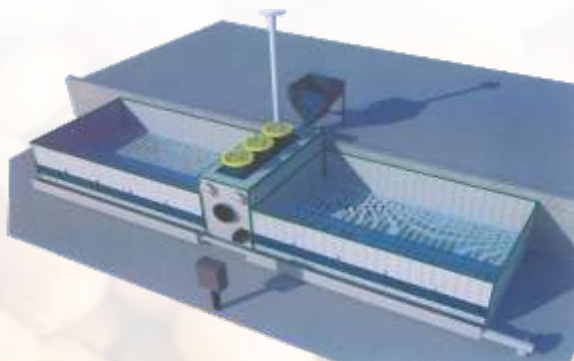

**CAPACIDADE:**  
8.000L cada caixa  
Comp. Total: 10m  
Largura: 2m  
Altura: 1m

## CHAPA

**CAPACIDADE:**  
15.000L cada caixa  
Comp. Total: 12m  
Largura: 3m  
Altura: 1m

**CAPACIDADE:**  
18.000L cada caixa  
Comp. Total: 12m  
Largura: 3m  
Altura: 1,25m

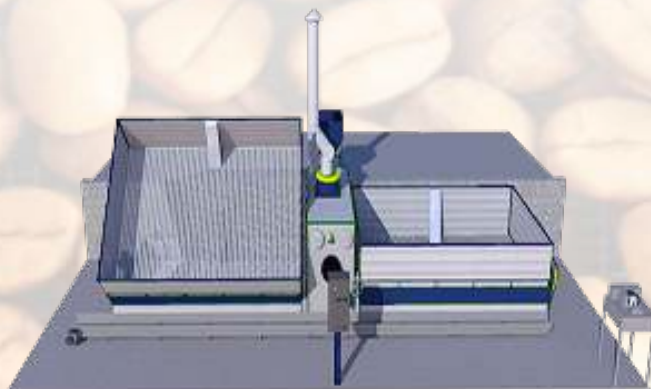

## SECADOR ESTÁTICO BASCULANTE

**CAPACIDADE:**  
8.000L cada caixa  
Comp. Total: 10m  
Largura: 2m  
Altura: 1m

**CAPACIDADE:**  
15.000L cada caixa  
Comp. Total: 12m  
Largura: 3m  
Altura: 1m

**CAPACIDADE:**  
18.000L cada caixa  
Comp. Total: 12m  
Largura: 3m  
Altura: 1,25m

- Elimina a etapa do terreiro;
- Secagem a fogo indireto;
- Reduz o tempo de colheita;
- Baixo custo de energia;
- Opção à lenha ou palhas de café;
- Sem engrenagens, polias ou correias;
- Melhor no mercado em custo e capacidade;
- Melhor qualidade, melhor preço;
- Eficácia comprovada, mais de 15 anos no mercado;
- Produto finalizável linhas do BNDES e mais alimentos;
- Mantém germinação dos grãos.

# Fumageiro



**Canos e Chaminés**



**Hélice co Pás de Ferro**



**Kit Exaustor  
900 e 1100**



**Aparelho de Estufa**



**Porta de Fornalha**



**Exaustor de Fibra**



**Flap com Motor**



**Mancais e Polias**



**Motores**



**Grelha de Refratário**



**Grelha de Ferro**



**Grampo de 20 e 25**



**Ventoinha**



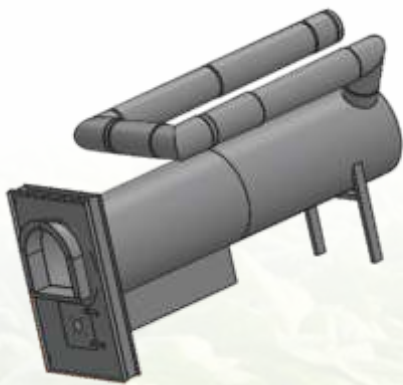

**Fornalha Modelo 01**



**Fornalha Frontal**

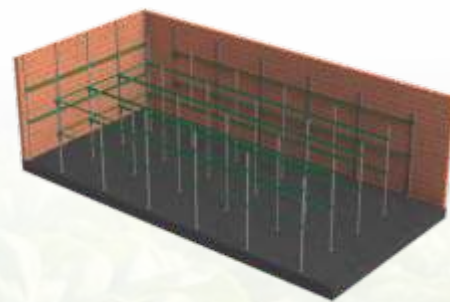

**Estaleiros de Grampo e Grade**



**Prensa de Fumo**

**FORTALECENDO  
PARCERIAS**



Site: [www.fortsulsc.com.br](http://www.fortsulsc.com.br)  
Fone: (48) 3660-0818  
E-mail: [comercial@fortsulsc.com.br](mailto:comercial@fortsulsc.com.br)

Rodovia SC 108, Km 330,95 - Bairro Murialdo - Orleans/SC

**MAQUIXANDE IND. DE MÁQUINAS AGRÍCOLAS E TRANSPORTES**  
CNPJ: 07.858.206/0001-04 - Inscr. Est.: 255.139.179